

MaskinSystem



Slitslåderesare C400

Machine description / technical specifications:

LANTECH CASE ERECTOR C-400



The C-400 is a case erector from the standard Lantech series. All standard equipment use proven techniques from the Lantech machine program. With this very compact case erector it is possible to handle a large number of different sizes with a high degree of reliability. Therefore the price / performance ratio is very good.

Its modest dimensions make integration in almost every production possible.

Converting into another box size takes about 1-2 minutes.

The components incorporated in our machine have been selected with the utmost care in order to guarantee our customers years of maximum performance from their installation.

The C-400 is different because:

Ergonomic blanks magazine:

In the ergonomic developed blanks magazine, blanks can easily be loaded due to the “walk-in” magazine. The magazine has in basic execution an effective length of 1090 mm. and with this length about 200 blanks of a B-flute (3 mm.) can be stored. The blanks are standing on side conveyors which transport them step by step towards the pick up section. The adjustments of the side guidings and the height adjustment of the blanks magazine are done by hand wheels. The adjustments can easily be read from counters and measure scales.

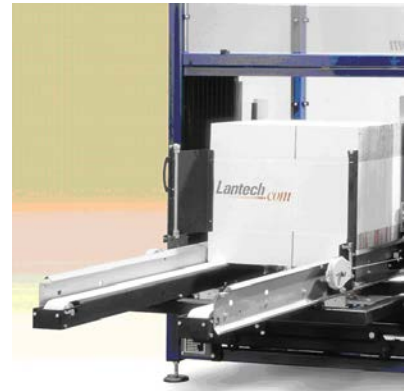

The vacuum pick up frame:

The vacuum pick up frame takes the unfolded blank on the long and the short side, by means of 8 suction cups. At this moment these two sides are still in one (vertical) plane. The position of the suction cups depends on the case dimensions and can easily be adjusted with locking pins.

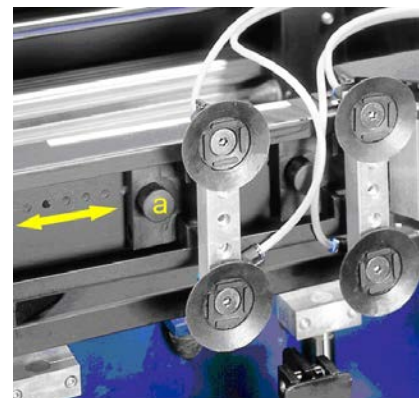

With the next movement the vacuum pick up frame hinges back to an angle of 90 degrees. This movement opens the blank to a case with open flaps. During this movement the blank is always held on two sides.

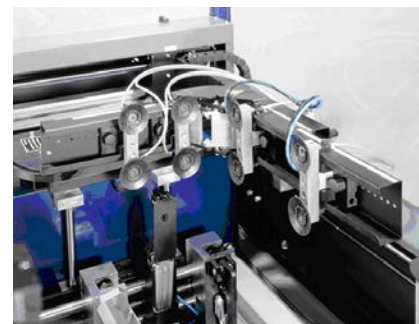

The flap folding section

Once the blank is opened completely, the short flaps are folded with the short flap folders. In the flap folder in the forward direction a photocell checks the presence of a blank. The distance between the short flap folders is determined by the length of the case and can simply be adjusted by handwheels with counters with linear dimension tables.

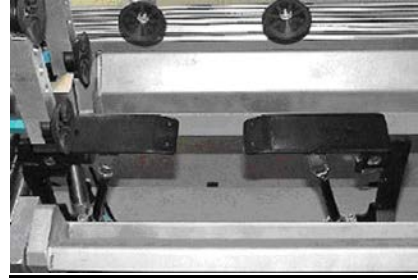

Instantly after that the long flap folders will come up. The distance between the long flap folders is adjustable by a hand wheel with a counter with linear dimension table. Hereafter the long flap folders will close long flaps and lock the case into a fixed position. This results in an optimal control over the case. Only after all flaps are closed the vacuum on the suction cups is turned off. Then the suction cups are pulled back 5 mm, to avoid wear on the cups while the case is being transported. Holding the case on two sides gives the case a higher stability, so that also cases of a poorer quality can be erected.

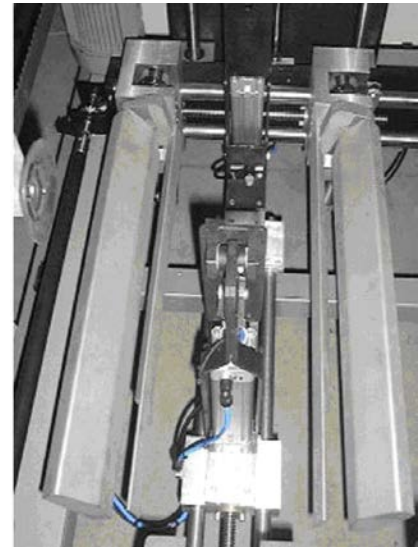

The pusher:

After the flaps are folded the pusher pushes the case in the direction of the closing section. During this movement the case is slid out of the long flap folders. During this movement the case is pushed between the two transport belts so that the case is constantly under perfect control.

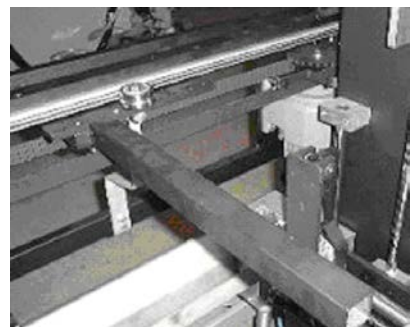

Closing unit:

The tape closing unit consists of two conveyor belts that transport the case while the tape is being applied on the bottom of the case. The belts are specially designed to prevent the case from going up.

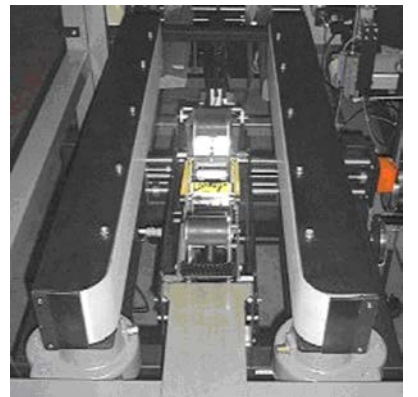

Technical specifications C-400:

Control box	:	Lantech (Colour Ral 7011)
Push buttons	:	Moeller
Safety switches	:	Moeller
Thermal cut-outs	:	Moeller
Magnetic switches	:	Moeller
Connecting terminals	:	Weidmüller
Cable trunking	:	closed with tulen
PLC	:	Siemens S7 S1200 Allan Bradley Micrologic 1000
Photo cells	:	Sick
Proximity switches	:	Sick
Pneumatic valves & cylinders	:	Festo
Reed contacts	:	Festo
Drives	:	Nord
Tape dispenser	:	Lantech TH-250 width 38–50 mm overlap 35 / 50 / 70 mm
Door switch	:	Schmersal

Deflections in execution and to be applied components, are not possible in this C-400.

Execution of the case erector C-400

- Operate start / stop / emergency stop.
- Welded frame
- Tape dispenser for closing the bottom side (50 mm width tape).
- Blanks magazine with side pushers
- Shielding transparent (clear)
- Check "perfectly erected case"
- Check "empty magazine" for blanks
- Check "run out of tape or tape broken"
- With photocell "discharge free"

Protective coating and environment:

Protective coating colour RAL nr. 5003 (blue) / RAL 7011 (grey)

The machine is suitable for operation in a dry environment at a temperature between +3°C and +40°C.

Specification of frame:

- Machine output from right or left, to be determined later.
- Delivery from the machine in conformity with CE norm.
- The machine will be delivered inclusive 1 manual.
(Operator manual in language of delivery. Technical manual in English).
More specimens are available against surcharge.

Options and execution:

- Complete detection with beacon lights
Almost run out of tape / broken , blank magazine almost empty / empty
- Other RAL colour than RAL 5003 / 7011
- Upper separator for poor quality cases, (C-height will be 250 mm)
- Square cases option incl. Upperseparator (C-height will be 250 mm)
- Minimum case width 140 mm.
- Discharge free on distance, machine in standby position

Case dimensions:

The case dimensions of cases that can be erected on this machine are:

	Minimum		Maximum	
Length (A)	200	mm	620	mm
Width (B)	150	mm	450	mm
Height (C)	150	mm	650	mm

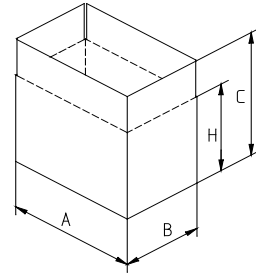

Corrugated quality:

B- and/or C-wave (double wall case to be reviewed upfront).

Capacity:

8 cases per minute.

Technical Specifications:

Electrical connection	:	3 x 400 - 50Hz. – N - earthed
Installed power	:	0,4 kW ±20%
Compressed air connection	:	1/4"
Air consumption	:	25 NI / case ±20%
Weight of the machine	:	555 kg.
Machine length	:	2310 mm.
Machine width	:	2370mm.
Machine height	:	1600 mm. ± 30mm
Machine Outfeed height	:	600 mm. ± 30mm



 **Smurfit Kappa**
Wellpack

Smurfit Kappa Wellpack
Box 1104, SE-241 26 Eslöv, Sweden
Tel +46 413 68000
Fax +46 413 68005
wellpack@smurfitkappa.se
www.wellpack.se