

MaskinSystem

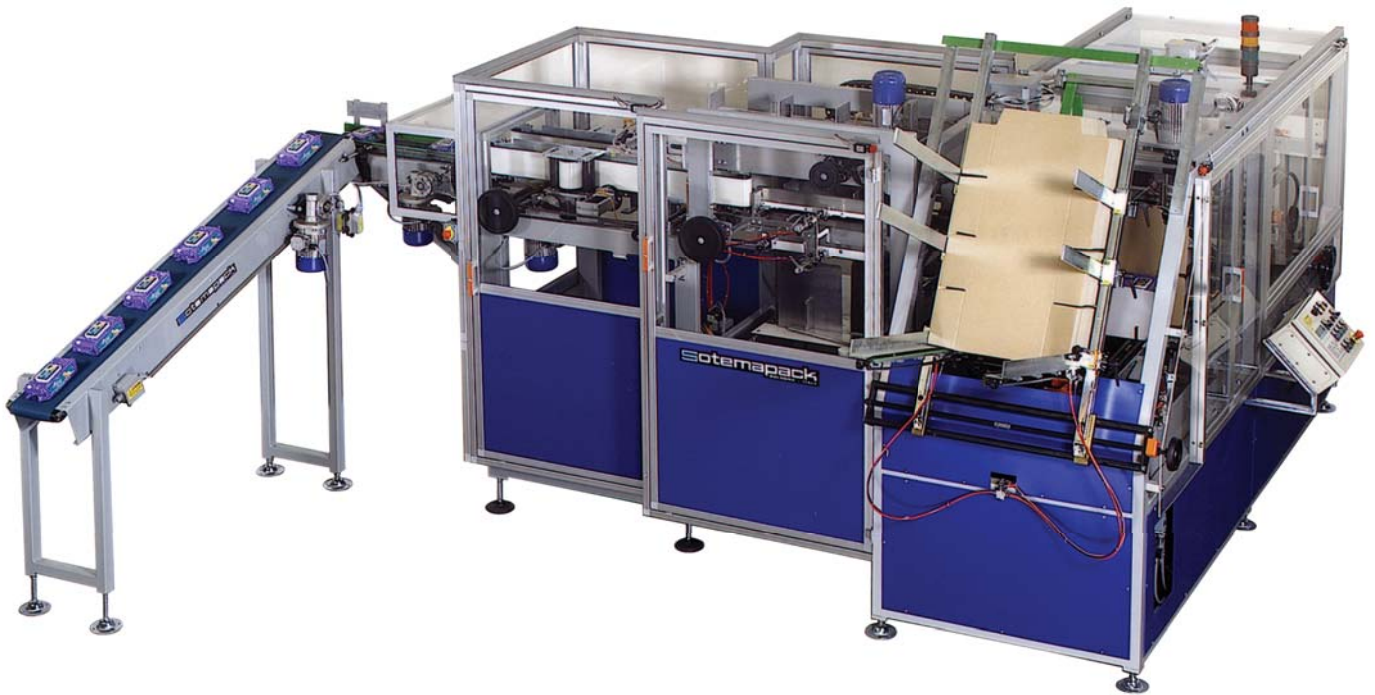

WA-MORBIWRAP

MORBIWRAP



MASKINFLÖDE / OPERATIVE FLOW / CYCLE DE TRAVAIL

PRODUKTER / PRODUCTS / PRODUITS

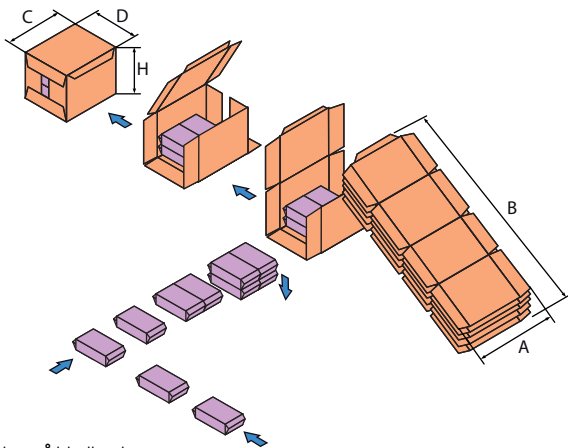

Alla mått är i mm

	STANDARD		MAJOR	
	MIN	MAX	MIN	MAX
AXB	300x500	800x1400	300x500	900x1580
C	200	500	200	600
D	120	320	120	420
H	100	360	120	360



Automatisk Wrap-Around Packare för vertikal rangering av påsar (Pillow-Pack) förpackningen utgår från ett plant stansat ark / **Automatic wrap around case packer, incorporating infeed with vertical stacking system. Ideally suited for soft pillow bags or flowrapped packs.** / *Machine automatique pour l'empilage et la confection successive sur découpe carton de sachets en matière molle (façon coussin) ou flow pack.*



Inmatningsenhet för hantering av produkter upp till 120 prod/min. / **High speed infeed suitable to receive up to 120 products /minute.** / *Système d'alimentation à haute vitesse, apte à recevoir jusqu'à 120 produits/min.*



Rangeringssystem med dubbla schakt för korrekt formning av mönstret detta möjliggör rangering samtidigt som inmatning. / **Stacking system with double hopper in order to get the right alignment of the products. Double hopper enables continuous stacking of product whilst transferring collation onto the blank.** / *Système d'empilage à double trémie qui permet d'obtenir un alignement parfait des produits.*



Mekanisk inmatningspusher av produkter in på det u-formade Wellarket. / **Transfer system of the products onto the carton blank by means of a mechanical pushing device.** / *Système de translation des produits sur le carton par l'intermédiaire d'un système de Transfert mécanique.*

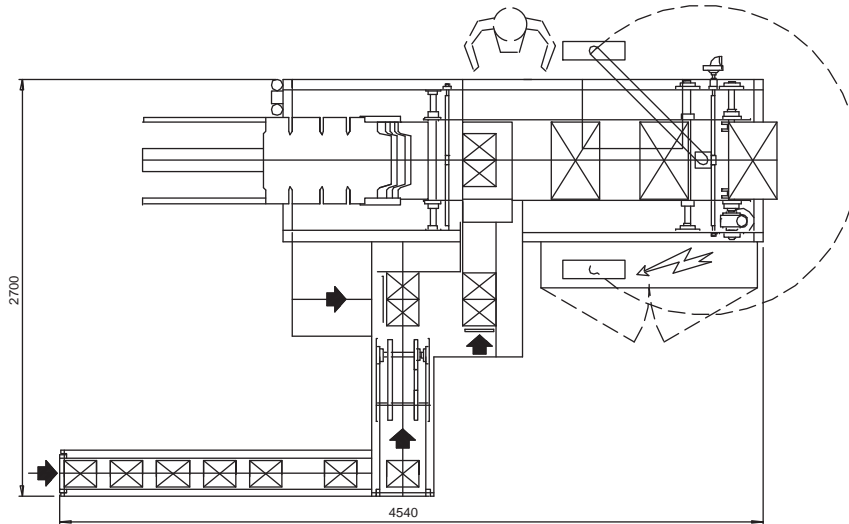

TEKNISK DATA / TECHNICAL DATA / CARACTERISTIQUES TECHNIQUES

Effektbehov / **Power requirement** / *Puissance installée*

Luftförbrukning / **Air consumption** / *Air comprimé*

Pneumatik / **Pneumatic** / *Pneumatique*

Plc / **Plc** / *Plc*

Display / **Display** / *Display*

Magasinskapacitet / **Magazin capacity** / *Capacité du magasin*

Hot Melt / **Hot melt** / *Groupe colle à chaud*

Hastighet Produkthinmatning / **infeed speed** / *Vitesse d'alimentation*

Staplingshastighet / **Stacker speed** / *Vitesse de l'empileur*

Hastighet / **Performance** / *Vitesse*

3x400 volt AC +N+PE, 50 Hz, 6 Kw

200 NI – 6 Bar

Metalwork

Siemens S7/313C

Proface touch screen

300st (3 mm.)

Robatech Concept B

Upp till 120 prod/min. / **Up to 120 products/min.** / *Jusqu'à 120 paquets / min.*

Upp till 30 lager / min. / **Up to 30 layers/min.** / *Jusqu'à 30 couches / min.*

Upp till 18 förp/min. / **Up to 18 packs/min.** / *Jusqu'à 18 paquets / min.*

OPTIONER/ OPTIONS AND UPGRADES / OPTIONS

- Föratomställning med servo / **Automatic changeover by servomotors** / *Réglages motorisés contrôlés par panneau opérateur*
- Rostfritt Utförande (Option) / **Stainless steel version available** / *Version en acier Inox*
- Specialkomponenter kan offereras / **Preferred components specs on request** / *Les composants sont personnalisés sur demande*



 **Smurfit Kappa**
Wellpack

Smurfit Kappa Wellpack
Box 1104, SE-241 26 Eslöv, Sweden
Tel +46 413 68000
Fax +46 413 68005
wellpack@smurfitkappa.se
www.wellpack.se